

COMPRESSOR

Displacement (cm ³)	34.42
Diameter (mm)	42.87
Stroke (mm)	23.85
Net Weight (Kg)	22.7
Oil type	ISO VG 46 ESTER
Oil charge (cm ³)	887

MOTOR

Approximate Power (CV)	1 5/8
Voltage/Frequency (V/Hz)	220V 50Hz
Voltage range (V)	187-264
Code	82,161
Type	CSR
Phase number	1 PH
Locked rotor current (A)	41.0
Main W. resist. at 25°C (Ω)	1.2
Start W. resist. at 25°C (Ω)	5.47

APPLICATION

Application	High back pressure
Refrigerant	R404A
Evaporating (°C)	-15 to 10
Expansion	Capillar/Valve
Comp. cooling	Fan cooled
Max. ambient temp. (°C)	43

NOMINAL PERFORMANCE

	CYCLE C	CYCLE D
Cooling capacity (kcal/h)	3639	4551
Input power (W)	2205	2300
EER (kcal/Wh)	1.65	1.97
COP (W/W)	1.91	2.30
Current (A)	11.01	11.50

TEST CONDITIONS

	CYCLE C	CYCLE D
Evaporating temp. (°C)	5.0	7.2
Condensing temp. (°C)	55.0	55.0
Liq.t. entering expan. (°C)	55.0	46.0
Ambient t. and return (°C)	32.0	35.0
Tens/Freq (V/Hz)	220V 50Hz	220V 50Hz

ELECTRICAL COMPONENTS

Relay	3ARR3 10AS3	RVA 3G..
Pick-Up (A)	180-195	180-195
Drop-Out (A)	40-105	40-105
Protector	CRA38008	GA3PLS00
Current (A)	36.5	36.5
Time check (seg)	7.5-14	6.0-16
Disc temp. (Open/Close) (°C)	130.0 / 69.0	125.0 / 69.0
Starting capacitor (μF/V)/F/V)	88-108 / 330	
Run capacitor (μF/V)	25 / 400	

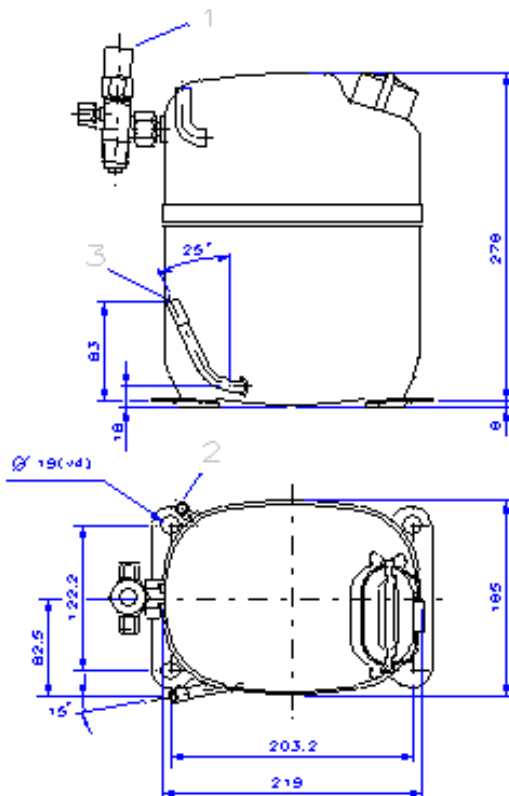
DIMENSIONS AND ELECTRICAL DIAGRAM

	DESIGNATION	INTERNAL DIAM. (MM)
1	Válv. Serv.	5/8" SAE
2	Service	9.6
3	Discharge	8.0

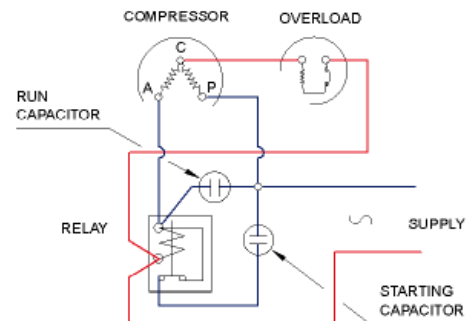
CSR

TEST CONDITIONS

Voltage/frequency	220V 50Hz
Ambient t. and return	35 °C
Liq.t. entering expan.	Subcooling 9 K

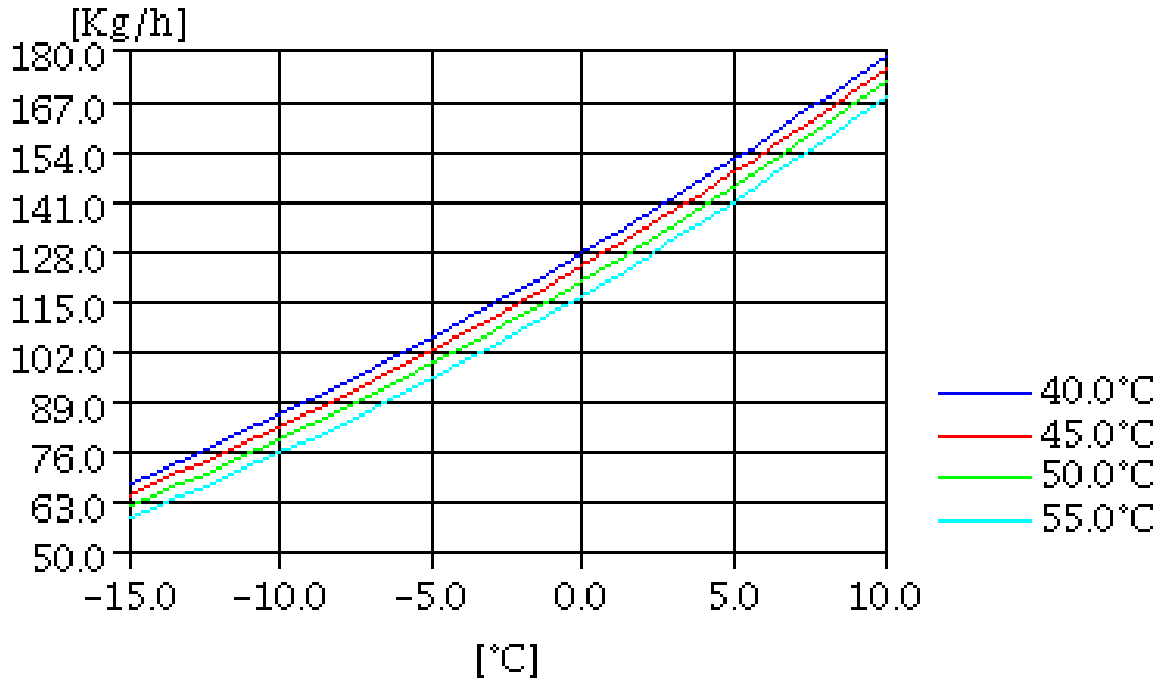
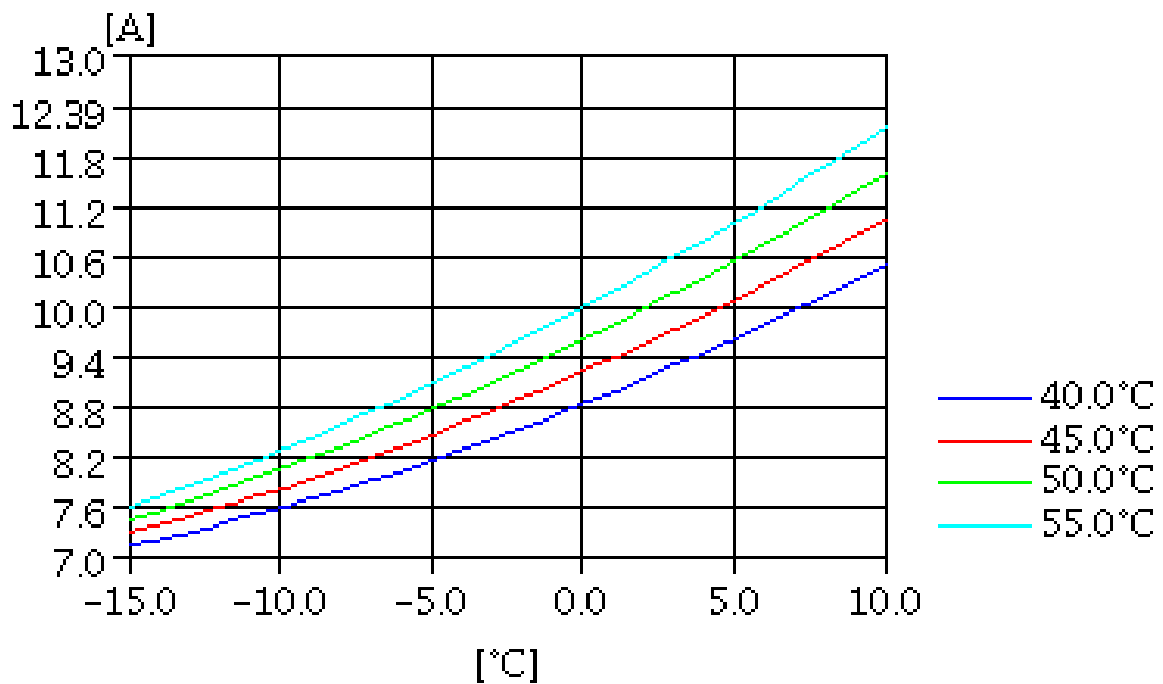
MASS FLOW

CONSUMPTION

TEST CONDITIONS

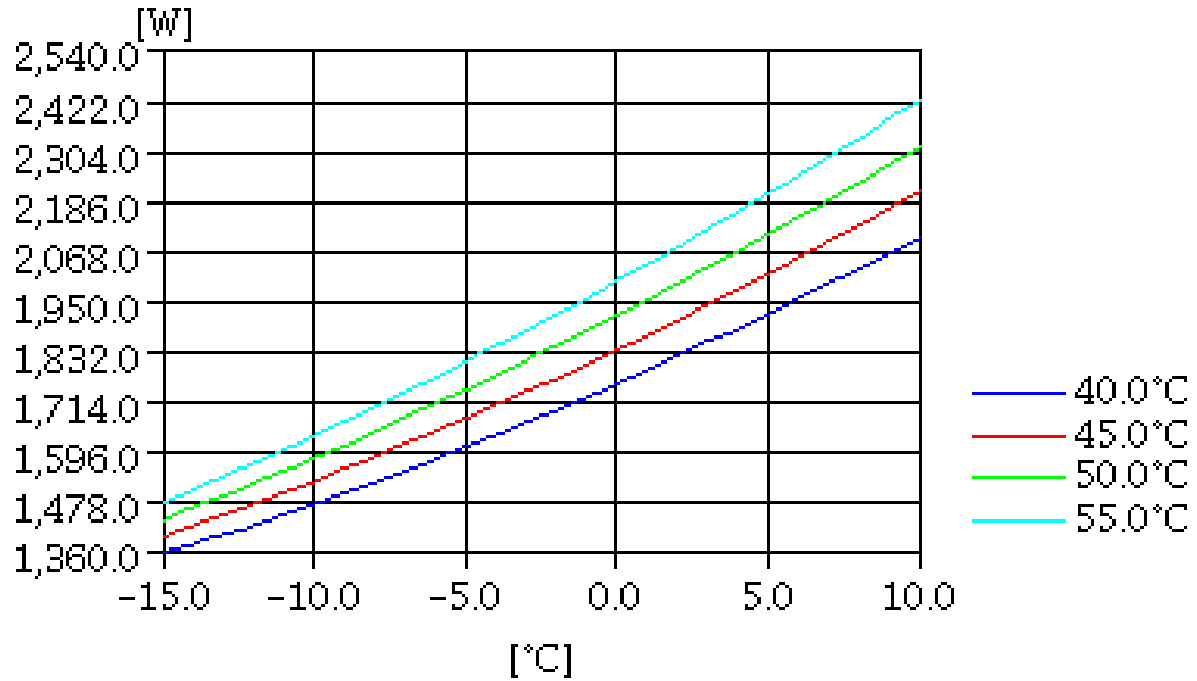
Voltage/frequency	220V 50Hz
Ambient t. and return	35 °C
Liq.t. entering expan.	Subcooling 9 K

INPUT W

COOLING CAPACITY
