



Compressor
Voltage Code : XG

FH4538Z-XG1A

High Temp. Commercial (HP)

380-420V 3~ 50Hz / 460V 3~ 60 Hz

R452A / R404A / R448A / R449A

FH4538ZXG1A

Conditions	Frequency	Nominal Cooling Capacity		Sound Power ISO3745 / ISO 3743-1
		Watts	BTU/h	
EN12900 / R452A	50 Hz / 60 Hz	7984 / 9259	27226 / 31575	76 dBA
EN12900 / R404A	50 Hz / 60 Hz	8011 / 9312	27318 / 31754	76 dBA
EN12900 / R448A	50 Hz / 60 Hz	8039 / 9344	27412 / 31862	76 dBA
EN12900 / R449A	50 Hz / 60 Hz	8039 / 9344	27412 / 31862	76 dBA

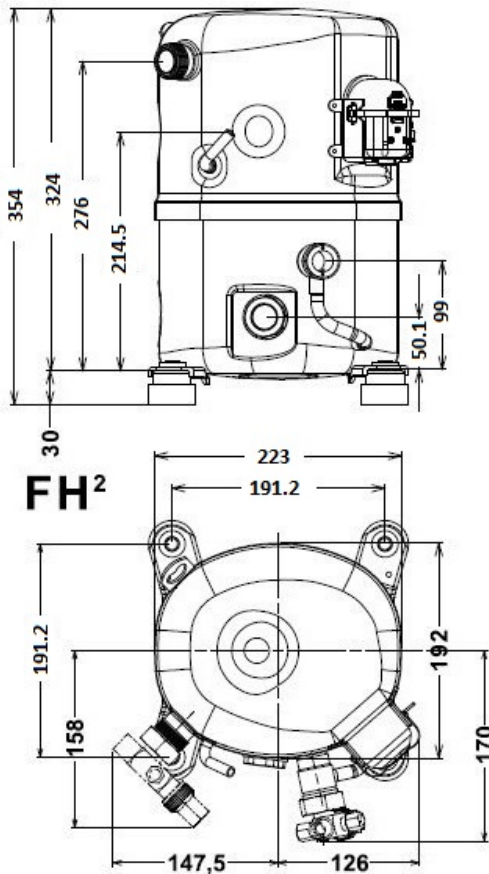

Displacement (cc)	63.0
Net Weight (Kg)	30.0
Oil Quantity (cc)	1140.0
Oil Type	Polyolester
Expansion Device	Capillary_Tube/Expansion_Valve
Cooling	Fan
Main Winding (Ohm)	7.9
Current	
RLA (A)	6.1 6.3
MCC (A)	8.9
LRA (A)	45
Electrical Equipment	TRI
Overload	Interne
Refrigerating connection for OD	
Suction Tube	22.2 (7/8")
Discharge Tube	12.7 (1/2")
Process Tube	6.35 (1/4")

* EN12900 : T°Cond. 50.0°C / T°Evap. 5.0°C / T°Return gas temp.. 20.0°C
T°Subcooling. 0.0K

Certificates :



Note : Tecumseh reserves the right to change information contained in this document without notification.



Tecumseh

FH4538Z-XG1A	Tension XG : 380-420V 3~ 50Hz / 460V 3~ 60 Hz
---------------------	--

Les performances sont données dans les conditions EN12900 :	Gaz aspirés :	20.0 °C
Condition Dew	Sous refroidissement :	0.0 K
The performance data are in EN12900 conditions :	Return gas :	20.0 °C
Dew Condition	Subcooling :	0.0 K

© 2020 Tecumseh Products Company
All rights reserved

50 Hz R452A

N°User-325

4 T condensation	5 T évaporation	(°C)	-25	-20	-15	-10	-5	0	5	10	15
30	1 P frigorifique	(Watt)	2861	3828	4953	6263	7784	9540	11560	13867	16489
	2 P absorbée	(W)	1398	1597	1779	1943	2090	2219	2332	2427	2506
	3 I absorbée	(A)	3.48	3.67	3.86	4.05	4.23	4.41	4.59	4.76	4.93
40	1 P frigorifique	(Watt)		3059	4073	5231	6559	8082	9827	11820	14086
	2 P absorbée	(W)		1689	1924	2142	2341	2522	2685	2831	2960
	3 I absorbée	(A)		3.78	4.04	4.29	4.53	4.78	5.02	5.25	5.49
50	1 P frigorifique	(Watt)			3150	4140	5258	6531	7984	9644	11537
	2 P absorbée	(W)			2032	2307	2563	2801	3020	3221	3404
	3 I absorbée	(A)			4.24	4.55	4.86	5.17	5.47	5.77	6.07
60	1 P frigorifique	(Watt)				3027	3918	4923	6068	7379	8882
	2 P absorbée	(W)				2439	2758	3056	3336	3597	3839
	3 I absorbée	(A)				4.84	5.22	5.59	5.95	6.32	6.68

60 Hz R452A

N°User-325

4 T condensation	5 T évaporation	(°C)	-25	-20	-15	-10	-5	0	5	10	15
30	1 P frigorifique	(Watt)	3439	4499	5759	7248	8999	11041	13406	16125	19228
	2 P absorbée	(W)	1663	1891	2110	2320	2525	2723	2917	3109	3298
	3 I absorbée	(A)	3.57	3.83	4.07	4.27	4.45	4.60	4.73	4.82	4.89
40	1 P frigorifique	(Watt)		3639	4767	6078	7603	9374	11421	13775	16466
	2 P absorbée	(W)		1973	2243	2503	2754	2999	3237	3470	3699
	3 I absorbée	(A)		3.88	4.20	4.48	4.75	4.98	5.19	5.37	5.52
50	1 P frigorifique	(Watt)			3687	4797	6076	7553	9259	11226	13485
	2 P absorbée	(W)			2316	2633	2939	3237	3526	3809	4085
	3 I absorbée	(A)			4.27	4.64	4.98	5.30	5.59	5.85	6.08
60	1 P frigorifique	(Watt)				3455	4464	5626	6970	8529	10332
	2 P absorbée	(W)				2697	3065	3423	3771	4110	4442
	3 I absorbée	(A)				4.73	5.16	5.56	5.93	6.28	6.59

1 = cooling capacity 2 = power input 3 = current 4 = condensing temperature 5 = evaporating temperature

Nota : Tecumseh se réserve le droit de modifier les informations contenues dans ce document sans préavis.

Note : Tecumseh reserves the right to change information contained in this document without notification.



Tecumseh

FH4538Z-XG1A	Tension XG : 380-420V 3~ 50Hz / 460V 3~ 60 Hz
---------------------	--

Les performances sont données dans les **conditions EN12900** :
 Condition Dew
 The performance data are in **EN12900 conditions** :
 Dew Condition

Gaz aspirés : 20.0 °C
 Sous refroidissement : 0.0 K
 Return gas : 20.0 °C
 Subcooling : 0.0 K

50 Hz R404A											
											N°User-324
4 T condensation	5 T évaporation	(°C)	-25	-20	-15	-10	-5	0	5	10	15
30	1 P frigorifique	(Watt)	3096	4075	5218	6547	8088	9864	11900	14218	16844
	2 P absorbée	(W)	1545	1749	1934	2095	2224	2315	2363	2359	2298
	3 I absorbée	(A)	3.56	3.83	4.05	4.24	4.40	4.52	4.60	4.65	4.66
40	1 P frigorifique	(Watt)	2339	3242	4262	5422	6747	8261	9988	11950	14174
	2 P absorbée	(W)	1591	1841	2080	2301	2499	2666	2796	2884	2921
	3 I absorbée	(A)	3.52	3.89	4.21	4.50	4.76	4.98	5.16	5.31	5.42
50	1 P frigorifique	(Watt)		2366	3259	4246	5351	6598	8011	9614	11431
	2 P absorbée	(W)		1906	2189	2461	2717	2951	3155	3323	3449
	3 I absorbée	(A)		3.91	4.34	4.73	5.08	5.40	5.68	5.93	6.14
60	1 P frigorifique	(Watt)			2227	3036	3917	4893	5989	7228	8635
	2 P absorbée	(W)			2286	2600	2905	3195	3463	3702	3907
	3 I absorbée	(A)			4.43	4.92	5.37	5.79	6.17	6.51	6.83

60 Hz R404A											
											N°User-324
4 T condensation	5 T évaporation	(°C)	-25	-20	-15	-10	-5	0	5	10	15
30	1 P frigorifique	(Watt)	3672	4866	6218	7759	9519	11527	13814	16409	19343
	2 P absorbée	(W)	1835	2115	2360	2569	2743	2883	2990	3063	3103
	3 I absorbée	(A)	3.57	3.83	4.07	4.27	4.45	4.60	4.73	4.82	4.89
40	1 P frigorifique	(Watt)	2708	3825	5048	6408	7935	9658	11608	13814	16307
	2 P absorbée	(W)	1799	2150	2466	2748	2997	3213	3397	3549	3670
	3 I absorbée	(A)	3.54	3.88	4.20	4.48	4.75	4.98	5.19	5.37	5.52
50	1 P frigorifique	(Watt)		2763	3844	5010	6289	7713	9312	11115	13152
	2 P absorbée	(W)		2148	2528	2875	3191	3475	3729	3952	4145
	3 I absorbée	(A)		3.87	4.27	4.64	4.98	5.30	5.59	5.85	6.08
60	1 P frigorifique	(Watt)			2651	3607	4626	5737	6970	8356	9923
	2 P absorbée	(W)			2576	2981	3355	3700	4015	4301	4559
	3 I absorbée	(A)			4.28	4.73	5.16	5.56	5.93	6.28	6.59

1 = cooling capacity 2 = power input 3 = current 4 = condensing temperature 5 = evaporating temperature

Nota : Tecumseh se réserve le droit de modifier les informations contenues dans ce document sans préavis.

Note : Tecumseh reserves the right to change information contained in this document without notification.

© 2020 Tecumseh Products Company
All rights reserved



Tecumseh

FH4538Z-XG1A	Tension XG : 380-420V 3~ 50Hz / 460V 3~ 60 Hz
---------------------	--

Les performances sont données dans les **conditions EN12900** :
 Condition Dew
 The performance data are in **EN12900 conditions** :
 Dew Condition

Gaz aspirés : 20.0 °C
 Sous refroidissement : 0.0 K
 Return gas : 20.0 °C
 Subcooling : 0.0 K

50 Hz R448A (*)											
											N°User-327
4 T condensation	5 T évaporation	(°C)	-25	-20	-15	-10	-5	0	5	10	15
30	1 P frigorifique	(Watt)	2558	3491	4594	5895	7422	9204	11267	13641	16354
	2 P absorbée	(W)	1360	1543	1715	1868	1996	2091	2144	2150	2100
	3 I absorbée	(A)	3.13	3.37	3.58	3.77	3.93	4.06	4.16	4.22	4.25
40	1 P frigorifique	(Watt)		2793	3794	4954	6301	7864	9671	11750	14129
	2 P absorbée	(W)		1630	1850	2059	2250	2415	2547	2638	2681
	3 I absorbée	(A)		3.42	3.73	4.00	4.26	4.48	4.67	4.83	4.94
50	1 P frigorifique	(Watt)			2955	3974	5142	6488	8039	9823	11869
	2 P absorbée	(W)			1951	2212	2462	2694	2900	3073	3206
	3 I absorbée	(A)			3.83	4.21	4.56	4.89	5.18	5.44	5.66
60	1 P frigorifique	(Watt)				2985	3974	5102	6397	7887	9600
	2 P absorbée	(W)				2339	2645	2940	3217	3468	3687
	3 I absorbée	(A)				4.36	4.82	5.26	5.67	6.04	6.38

60 Hz R448A (*)											
											N°User-327
4 T condensation	5 T évaporation	(°C)	-25	-20	-15	-10	-5	0	5	10	15
30	1 P frigorifique	(Watt)	3033	4168	5475	6986	8735	10755	13081	15744	18780
	2 P absorbée	(W)	1615	1866	2091	2290	2461	2603	2714	2792	2837
	3 I absorbée	(A)	3.14	3.38	3.60	3.81	3.99	4.16	4.29	4.40	4.47
40	1 P frigorifique	(Watt)		3295	4494	5855	7410	9195	11241	13583	16254
	2 P absorbée	(W)		1903	2193	2459	2698	2910	3093	3246	3367
	3 I absorbée	(A)		3.44	3.73	4.01	4.27	4.51	4.72	4.91	5.06
50	1 P frigorifique	(Watt)			3488	4690	6044	7585	9344	11356	13654
	2 P absorbée	(W)			2253	2584	2891	3173	3428	3655	3852
	3 I absorbée	(A)			3.81	4.17	4.51	4.84	5.14	5.41	5.65
60	1 P frigorifique	(Watt)				3546	4692	5980	7444	9118	11035
	2 P absorbée	(W)				2680	3054	3404	3730	4030	4303
	3 I absorbée	(A)				4.26	4.70	5.12	5.51	5.88	6.22

1 = cooling capacity 2 = power input 3 = current 4 = condensing temperature 5 = evaporating temperature

(*) Veuillez vous référer strictement aux Recommandations d'Utilisation et Bulletins Marketing Tecumseh du fait de la température de refoulement élevée pour les applications LBP.
 (*) Due to very high discharge temperature especially on LBP conditions, please strictly refer to Tecumseh Guidelines & Marketing Bulletin when using this refrigerant.

Nota : Tecumseh se réserve le droit de modifier les informations contenues dans ce document sans préavis.

Note : Tecumseh reserves the right to change information contained in this document without notification.

© 2020 Tecumseh Products Company
All rights reserved



Tecumseh

FH4538Z-XG1A

Tension XG : 380-420V 3~ 50Hz / 460V 3~ 60 Hz

Les performances sont données dans les **conditions EN12900** :
Condition Dew

Gaz aspirés : 20.0 °C
Sous refroidissement : 0.0 K

The performance data are in **EN12900 conditions** :
Dew Condition

Return gas : 20.0 °C
Subcooling : 0.0 K

50 Hz R449A (*)

N°User-326

4 T condensation	5 T évaporation	(°C)	-25	-20	-15	-10	-5	0	5	10	15
30	1 P frigorifique	(Watt)	2558	3491	4594	5895	7422	9204	11267	13641	16354
	2 P absorbée	(W)	1360	1543	1715	1868	1996	2091	2144	2150	2100
	3 I absorbée	(A)	3.13	3.37	3.58	3.77	3.93	4.06	4.16	4.22	4.25
40	1 P frigorifique	(Watt)		2793	3794	4954	6301	7864	9671	11750	14129
	2 P absorbée	(W)		1630	1850	2059	2250	2415	2547	2638	2681
	3 I absorbée	(A)		3.42	3.73	4.00	4.26	4.48	4.67	4.83	4.94
50	1 P frigorifique	(Watt)			2955	3974	5142	6488	8039	9823	11869
	2 P absorbée	(W)			1951	2212	2462	2694	2900	3073	3206
	3 I absorbée	(A)			3.83	4.21	4.56	4.89	5.18	5.44	5.66
60	1 P frigorifique	(Watt)				2985	3974	5102	6397	7887	9600
	2 P absorbée	(W)				2339	2645	2940	3217	3468	3687
	3 I absorbée	(A)				4.36	4.82	5.26	5.67	6.04	6.38

60 Hz R449A (*)

N°User-326

4 T condensation	5 T évaporation	(°C)	-25	-20	-15	-10	-5	0	5	10	15
30	1 P frigorifique	(Watt)	3033	4168	5475	6986	8735	10755	13081	15744	18780
	2 P absorbée	(W)	1615	1866	2091	2290	2461	2603	2714	2792	2837
	3 I absorbée	(A)	3.14	3.38	3.60	3.81	3.99	4.16	4.29	4.40	4.47
40	1 P frigorifique	(Watt)		3295	4494	5855	7410	9195	11241	13583	16254
	2 P absorbée	(W)		1903	2193	2459	2698	2910	3093	3246	3367
	3 I absorbée	(A)		3.44	3.73	4.01	4.27	4.51	4.72	4.91	5.06
50	1 P frigorifique	(Watt)			3488	4690	6044	7585	9344	11356	13654
	2 P absorbée	(W)			2253	2584	2891	3173	3428	3655	3852
	3 I absorbée	(A)			3.81	4.17	4.51	4.84	5.14	5.41	5.65
60	1 P frigorifique	(Watt)				3546	4692	5980	7444	9118	11035
	2 P absorbée	(W)				2680	3054	3404	3730	4030	4303
	3 I absorbée	(A)				4.26	4.70	5.12	5.51	5.88	6.22

1 = cooling capacity 2 = power input 3 = current 4 = condensing temperature 5 = evaporating temperature

(*) Veuillez vous référer strictement aux Recommandations d'Utilisation et Bulletins Marketing Tecumseh du fait de la température de refoulement élevée pour les applications LBP.

(*) Due to very high discharge temperature especially on LBP conditions, please strictly refer to Tecumseh Guidelines & Marketing Bulletin when using this refrigerant.

Nota : Tecumseh se réserve le droit de modifier les informations contenues dans ce document sans préavis.

Note : Tecumseh reserves the right to change information contained in this document without notification.

© 2020 Tecumseh Products Company
All rights reserved