



Compressor  
Voltage Code : FZ

# AJ4492N-FZ

High Temp. Commercial (HP)

220 - 240V 1~ 50 Hz

R1234yf / R134a / R513A

## AJ4492N-FZ1B

Conditions	Frequency	Nominal Cooling Capacity		Sound Power ISO3745 / ISO 3743-1
		Watts	BTU/h	
CECOMAF / R1234yf	50 Hz	1980	6751	58 dBA
CECOMAF / R134a	50 Hz	2012	6860	58 dBA
CECOMAF / R513A	50 Hz	2041	6959	58 dBA

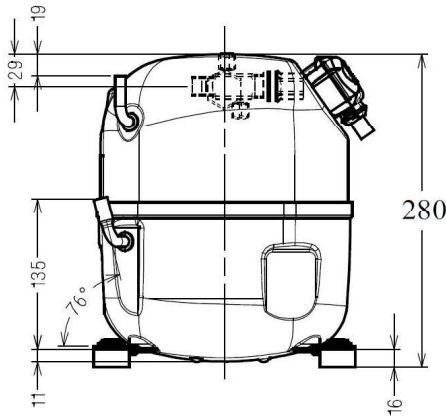

<b>Displacement (cc)</b>	25,95
<b>Net Weight (Kg)</b>	19.8
<b>Oil Quantity (cc)</b>	475.0
<b>Oil Type</b>	Polyolester
<b>Expansion Device</b>	Capillary_Tube/Expansion_Valve
<b>Cooling</b>	Fan
<b>Main Winding (Ohm)</b>	2.9
<b>Start Winding (Ohm)</b>	12.8
<b>Current</b>	
RLA (A)	5.9
MCC (A)	9
LRA (A)	28
<b>Electrical Equipment</b>	CSIR
<b>Overload</b>	MST18AIN
Time Check	7.5s - 14s / 20.7 A
Open Temp	120° C
Close Temp	69° C
Optional	T0750
<b>Start Capacitor</b>	64 µF / 330 V
<b>Potential Relay</b>	RVA4G**
Pick Up	180/195V
Drop Out	40/105V
Optional	/
<b>Refrigerating connection for</b>	
Suction Tube	15.9 (5/8")
Discharge Tube	7.9 (5/16")
Process Tube	6.35 (1/4")

\* CECOMAF : T°Cond. 55.0°C / T°Evap. 5.0°C / T°Return gas temp.. 32.0°C  
T°Subcooling. 0.0K

Certificates :



Note : Tecumseh reserves the right to change information contained in this document without notification.



**Tecumseh**

<b>AJ4492N-FZ</b>	<b>Tension FZ : 220 - 240V 1~ 50 Hz</b>
-------------------	---

Les performances sont données dans les **conditions CECOMAF** :  
 Condition Dew  
 The performance data are in **CECOMAF conditions** :  
 Dew Condition

Gaz aspirés : 32.0 °C  
 Sous refroidissement : 0.0 K  
 Return gas : 32.0 °C  
 Subcooling : 0.0 K

© 2024 Tecumseh Products Company  
All rights reserved

**50 Hz R1234yf**

**N°284LS-FZ**

4   T condensation	5   T évaporation	(°C)	-25	-20	-15	-10	-5	0	5	10	15
<b>30</b>	1   P frigorifique	(Watt)	694	959	1260	1603	1996	2446	2961	3548	4213
	2   P absorbée	(W)	461	526	581	629	673	717	764	818	881
	3   I absorbée	(A)	4.01	4.20	4.37	4.52	4.67	4.80	4.92	5.02	5.12
<b>40</b>	1   P frigorifique	(Watt)		768	1050	1366	1723	2128	2590	3115	3711
	2   P absorbée	(W)		533	613	682	744	802	859	919	985
	3   I absorbée	(A)		4.16	4.42	4.68	4.92	5.15	5.36	5.57	5.76
<b>50</b>	1   P frigorifique	(Watt)			827	1111	1427	1784	2188	2647	3169
	2   P absorbée	(W)			616	714	801	881	956	1030	1106
	3   I absorbée	(A)			4.42	4.77	5.11	5.43	5.74	6.04	6.33
<b>60</b>	1   P frigorifique	(Watt)				854	1126	1428	1770	2159	2602
	2   P absorbée	(W)				715	836	945	1045	1141	1236
	3   I absorbée	(A)				4.79	5.23	5.65	6.06	6.46	6.84

**50 Hz R134a**

**N°284LS-FZA**

4   T condensation	5   T évaporation	(°C)	-25	-20	-15	-10	-5	0	5	10	15
<b>30</b>	1   P frigorifique	(Watt)	613	858	1153	1507	1931	2432	3020	3703	4490
	2   P absorbée	(W)	415	479	536	588	636	680	723	764	804
	3   I absorbée	(A)	4.32	4.39	4.47	4.58	4.70	4.85	5.01	5.20	5.40
<b>40</b>	1   P frigorifique	(Watt)		692	963	1281	1656	2097	2612	3211	3903
	2   P absorbée	(W)		483	562	634	701	763	823	880	935
	3   I absorbée	(A)		4.37	4.53	4.71	4.91	5.13	5.37	5.62	5.90
<b>50</b>	1   P frigorifique	(Watt)			756	1044	1377	1763	2211	2732	3334
	2   P absorbée	(W)			560	657	748	834	915	993	1068
	3   I absorbée	(A)			4.55	4.81	5.08	5.37	5.69	6.02	6.37
<b>60</b>	1   P frigorifique	(Watt)				791	1087	1424	1812	2260	2777
	2   P absorbée	(W)				652	772	886	994	1098	1198
	3   I absorbée	(A)				4.87	5.22	5.59	5.97	6.38	6.81

1 = cooling capacity 2 = power input 3 = current 4 = condensing temperature 5 = evaporating temperature

**Nota : Tecumseh se réserve le droit de modifier les informations contenues dans ce document sans préavis.**

**Note : Tecumseh reserves the right to change information contained in this document without notification.**



**Tecumseh**

<b>AJ4492N-FZ</b>	<b>Tension FZ : 220 - 240V 1~ 50 Hz</b>
-------------------	---

Les performances sont données dans les <b>conditions CECOMAF</b> :	Gaz aspirés :	32.0 °C
Condition Dew	Sous refroidissement :	0.0 K
The performance data are in <b>CECOMAF conditions</b> :	Return gas :	32.0 °C
Dew Condition	Subcooling :	0.0 K

**50 Hz R513A**

**N°3304**

4   T condensation	5   T évaporation	(°C)	-25	-20	-15	-10	-5	0	5	10	15
<b>30</b>	1   P frigorifique	(Watt)	724	984	1290	1653	2082	2585	3170	3848	4627
	2   P absorbée	(W)	458	525	584	637	686	732	776	820	864
	3   I absorbée	(A)	4.32	4.39	4.47	4.58	4.70	4.85	5.01	5.20	5.40
<b>40</b>	1   P frigorifique	(Watt)		787	1069	1392	1766	2200	2704	3285	3953
	2   P absorbée	(W)		521	604	679	749	815	877	938	999
	3   I absorbée	(A)		4.37	4.53	4.71	4.91	5.13	5.37	5.62	5.90
<b>50</b>	1   P frigorifique	(Watt)			829	1123	1453	1829	2259	2753	3320
	2   P absorbée	(W)			594	697	794	885	972	1056	1138
	3   I absorbée	(A)			4.55	4.81	5.08	5.37	5.69	6.02	6.37
<b>60</b>	1   P frigorifique	(Watt)				833	1129	1456	1823	2240	2716
	2   P absorbée	(W)				686	816	938	1055	1168	1278
	3   I absorbée	(A)				4.87	5.22	5.59	5.97	6.38	6.81

© 2024 Tecumseh Products Company  
All rights reserved

1 = cooling capacity 2 = power input 3 = current 4 = condensing temperature 5 = evaporating temperature

**Nota : Tecumseh se réserve le droit de modifier les informations contenues dans ce document sans préavis.**

**Note : Tecumseh reserves the right to change information contained in this document without notification.**