



Compressor  
Voltage Code : FZ

**AJ2432P-FZ**

Low Temp. Commercial (BP)

220 - 240V 1~ 50 Hz

R452A / R404A / R455A / R454C

**AJ2432P-FZ3A**

Conditions	Frequency	Nominal Cooling Capacity		Sound Power ISO3745 / ISO 3743-1
		Watts	BTU/h	
CECOMAF / R452A	50 Hz	476	1622	56 dBA
CECOMAF / R404A	50 Hz	516	1759	56 dBA
CECOMAF / R455A	50 Hz	432	1473	56 dBA
CECOMAF / R454C	50 Hz	411	1401	56 dBA

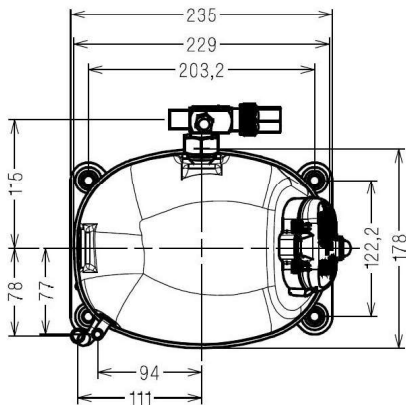
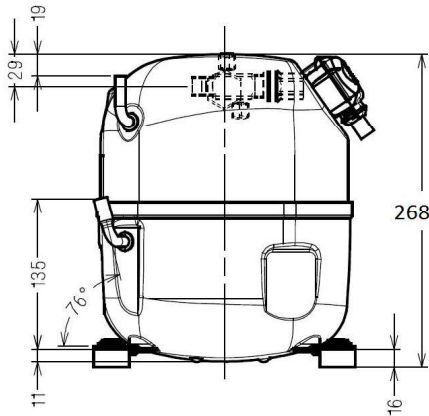

\* CECOMAF : T°Cond. 55.0°C / T°Evap. -25.0°C / T°Return gas temp.. 32.0°C  
T°Subcooling. 0.0K

Certificates :



<b>Displacement (cc)</b>	18,3
<b>Net Weight (Kg)</b>	19.8
<b>Oil Quantity (cc)</b>	475.0
<b>Oil Type</b>	Polyolester
<b>Expansion Device</b>	Capillary_Tube/Expansion_Valve
<b>Cooling</b>	Fan
<b>Main Winding (Ohm)</b>	4.5
<b>Start Winding (Ohm)</b>	9.8
<b>Current</b>	
RLA (A)	2,5
MCC (A)	5,9
LRA (A)	20,8
<b>Electrical Equipment</b>	CSR
<b>Overload</b>	T0348
Time Check	7,5s - 14s / 15,4 A
Open Temp	105° C
Close Temp	52° C
Optional	MRA38111
<b>Start Capacitor</b>	88 µF / 330 V
<b>Run Capacitor</b>	15 µF / 400 V
<b>Potential Relay</b>	RVA4P**
Pick Up	300/328V
Drop Out	60/121V
<b>Refrigerating connection for</b>	
Suction Tube	12.7 (1/2")
Discharge Tube	7.9 (5/16")
Process Tube	6.35 (1/4")

Note : Tecumseh reserves the right to change information contained in this document without notification.



**Tecumseh**

<b>AJ2432P-FZ</b>	<b>Tension FZ : 220 - 240V 1~ 50 Hz</b>
-------------------	---

Les performances sont données dans les **conditions CECOMAF** :  
 Condition Dew  
 The performance data are in **CECOMAF conditions** :  
 Dew Condition

Gaz aspirés : 32.0 °C  
 Sous refroidissement : 0.0 K  
 Return gas : 32.0 °C  
 Subcooling : 0.0 K

© 2024 Tecumseh Products Company  
All rights reserved

**50 Hz R452A**

**N°3600**

4   T condensation	5   T évaporation	(°C)	<b>-40</b>	<b>-35</b>	<b>-30</b>	<b>-25</b>	<b>-20</b>	<b>-15</b>	<b>-10</b>
<b>30</b>	1   P frigorifique	(Watt)	326	477	665	896	1175	1506	1894
	2   P absorbée	(W)	336	390	444	500	560	623	693
	3   I absorbée	(A)	1.52	1.74	1.98	2.24	2.53	2.83	3.16
<b>40</b>	1   P frigorifique	(Watt)		369	532	732	974	1264	1606
	2   P absorbée	(W)		384	452	522	596	675	760
	3   I absorbée	(A)		1.73	2.02	2.34	2.67	3.03	3.40
<b>50</b>	1   P frigorifique	(Watt)			394	560	764	1009	1302
	2   P absorbée	(W)			440	523	611	704	804
	3   I absorbée	(A)			1.99	2.36	2.74	3.14	3.57
<b>60</b>	1   P frigorifique	(Watt)				393	554	752	993
	2   P absorbée	(W)				505	605	711	825
	3   I absorbée	(A)				2.30	2.74	3.19	3.65

**50 Hz R404A**

**N°3601**

4   T condensation	5   T évaporation	(°C)	<b>-40</b>	<b>-35</b>	<b>-30</b>	<b>-25</b>	<b>-20</b>	<b>-15</b>	<b>-10</b>
<b>30</b>	1   P frigorifique	(Watt)	369	530	730	972	1260	1598	1990
	2   P absorbée	(W)	340	398	456	516	577	641	709
	3   I absorbée	(A)	1.63	1.87	2.13	2.40	2.69	3.00	3.32
<b>40</b>	1   P frigorifique	(Watt)		413	583	791	1038	1330	1670
	2   P absorbée	(W)		397	467	540	616	696	781
	3   I absorbée	(A)		1.87	2.18	2.51	2.85	3.21	3.58
<b>50</b>	1   P frigorifique	(Watt)			436	607	812	1056	1343
	2   P absorbée	(W)			458	543	633	728	830
	3   I absorbée	(A)			2.16	2.54	2.93	3.34	3.77
<b>60</b>	1   P frigorifique	(Watt)				426	588	783	1016
	2   P absorbée	(W)				528	631	740	857
	3   I absorbée	(A)				2.50	2.94	3.40	3.88

1 = cooling capacity 2 = power input 3 = current 4 = condensing temperature 5 = evaporating temperature

**Nota : Tecumseh se réserve le droit de modifier les informations contenues dans ce document sans préavis.**

**Note : Tecumseh reserves the right to change information contained in this document without notification.**



**Tecumseh**

<b>AJ2432P-FZ</b>	<b>Tension FZ : 220 - 240V 1~ 50 Hz</b>
-------------------	---

Les performances sont données dans les <b>conditions CECOMAF</b> :	Gaz aspirés :	32.0 °C
Condition Dew	Sous refroidissement :	0.0 K
The performance data are in <b>CECOMAF conditions</b> :	Return gas :	32.0 °C
Dew Condition	Subcooling :	0.0 K

© 2024 Tecumseh Products Company  
All rights reserved

### 50 Hz R455A

**N°3325**

4   T condensation	5   T évaporation	(°C)	<b>-40</b>	<b>-35</b>	<b>-30</b>	<b>-25</b>	<b>-20</b>	<b>-15</b>	<b>-10</b>
<b>30</b>	1   P frigorifique	(Watt)	287	422	590	797	1047	1345	1695
	2   P absorbée	(W)	288	337	386	436	486	536	587
	3   I absorbée	(A)	1.35	1.55	1.79	2.04	2.28	2.51	2.69
<b>40</b>	1   P frigorifique	(Watt)	204	324	472	655	876	1140	1452
	2   P absorbée	(W)	268	323	382	444	510	578	649
	3   I absorbée	(A)	1.29	1.50	1.76	2.06	2.36	2.67	2.95
<b>50</b>	1   P frigorifique	(Watt)		223	350	507	697	926	1199
	2   P absorbée	(W)		296	363	435	513	597	687
	3   I absorbée	(A)		1.41	1.68	2.02	2.38	2.77	3.15
<b>60</b>	1   P frigorifique	(Watt)			229	358	516	709	940
	2   P absorbée	(W)			331	411	500	597	703
	3   I absorbée	(A)			1.54	1.90	2.32	2.78	3.26

### 50 Hz R454C

**N°3324**

4   T condensation	5   T évaporation	(°C)	<b>-40</b>	<b>-35</b>	<b>-30</b>	<b>-25</b>	<b>-20</b>	<b>-15</b>	<b>-10</b>
<b>30</b>	1   P frigorifique	(Watt)	275	403	561	752	981	1251	1565
	2   P absorbée	(W)	281	327	372	417	463	510	558
	3   I absorbée	(A)	1.35	1.52	1.71	1.91	2.13	2.36	2.60
<b>40</b>	1   P frigorifique	(Watt)	193	309	449	619	823	1064	1346
	2   P absorbée	(W)	264	317	372	429	488	550	616
	3   I absorbée	(A)	1.26	1.49	1.73	1.98	2.25	2.53	2.83
<b>50</b>	1   P frigorifique	(Watt)		211	333	481	658	868	1116
	2   P absorbée	(W)		292	355	422	494	570	651
	3   I absorbée	(A)		1.36	1.66	1.96	2.28	2.62	2.97
<b>60</b>	1   P frigorifique	(Watt)			218	341	490	669	881
	2   P absorbée	(W)			323	399	481	569	665
	3   I absorbée	(A)			1.50	1.86	2.23	2.62	3.02

1 = cooling capacity 2 = power input 3 = current 4 = condensing temperature 5 = evaporating temperature

**Nota : Tecumseh se réserve le droit de modifier les informations contenues dans ce document sans préavis.**

**Note : Tecumseh reserves the right to change information contained in this document without notification.**